

REV	DESCRIPTION	DRAWN	DATE

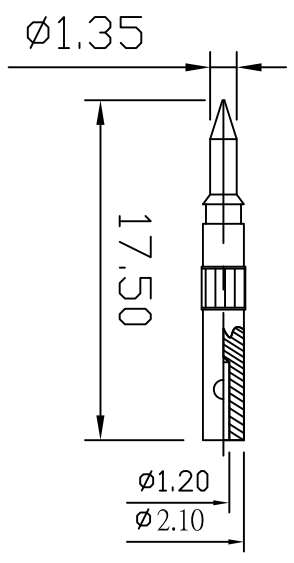
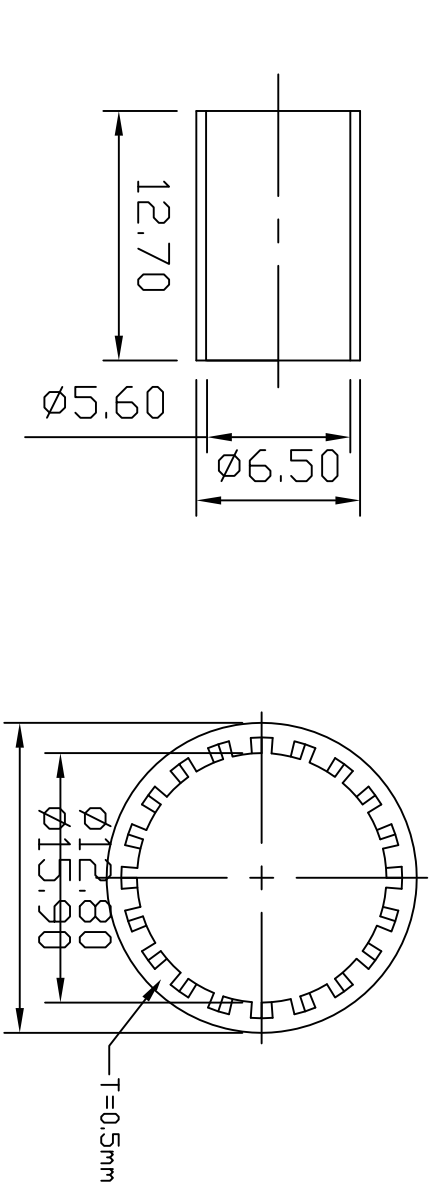
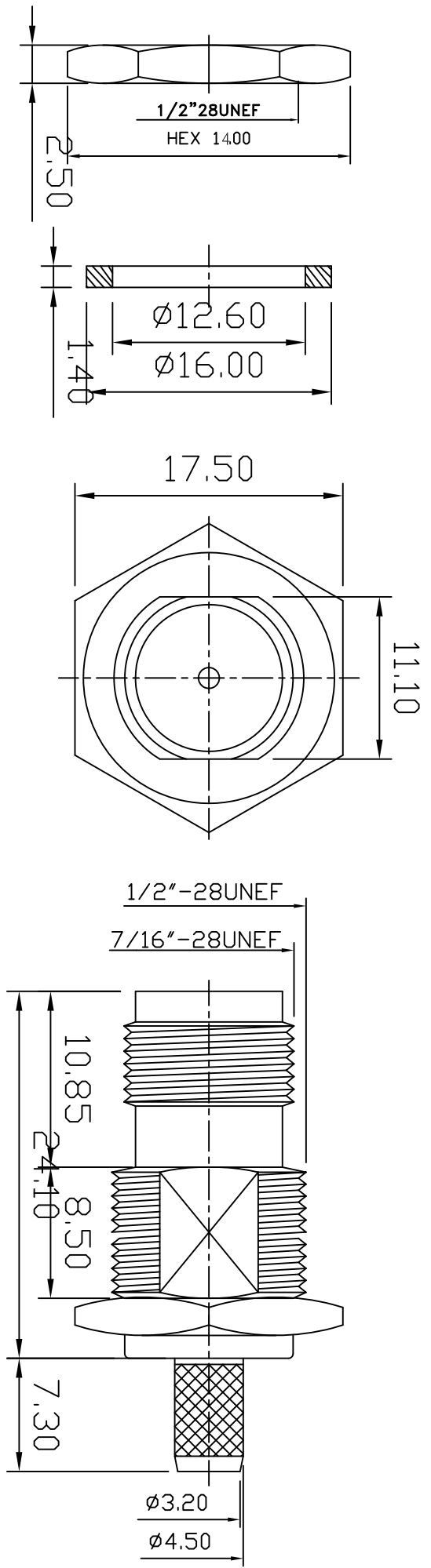

NO	Description	Qty	Material	Finish
3	DIELECTRIC	1	TEFLON	NONE
2	PIN	1	BRASS	GOLD
1	BDDY	1	BRASS	NICKEL

R&D

\* MAJOR DIMENSION  
 UNLESS OTHERWISE NOTED TOLERANCES  
 0.5-6 = ±0.2  
 6-30 = ±0.4  
 30-120 = ±0.6  
 120-315 = ±1.0  
 ANGLES = ±1.0

SCALE	4/1	UNIT	MM
-------	-----	------	----

APPROVED	CASH	
CHECKED	LYDIA	
DRAWN	PEN	TITLE
DRAWN DATE 09/03/13		TNC FEMALE RP BULKHEAD CRIMP
DRAWING NO.	TNC-1514-3-F-RP-TGN	REV
		SL A